

**M&**



H

---

1€



H

---



H

---

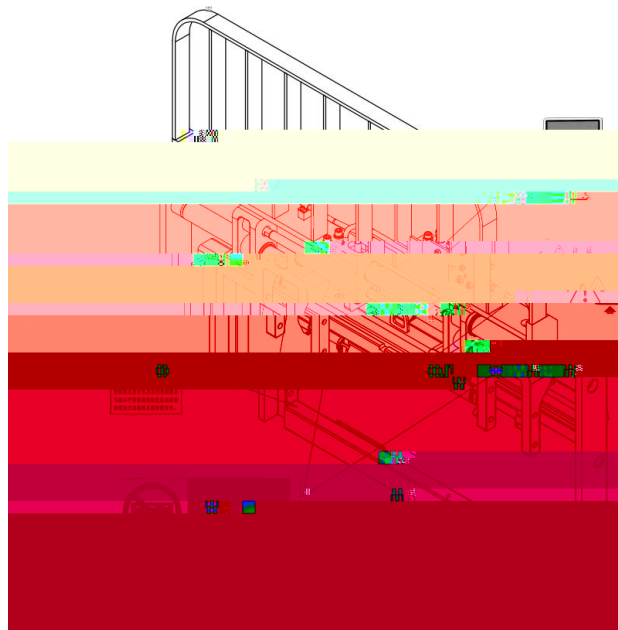



H

---



H

---



H

---



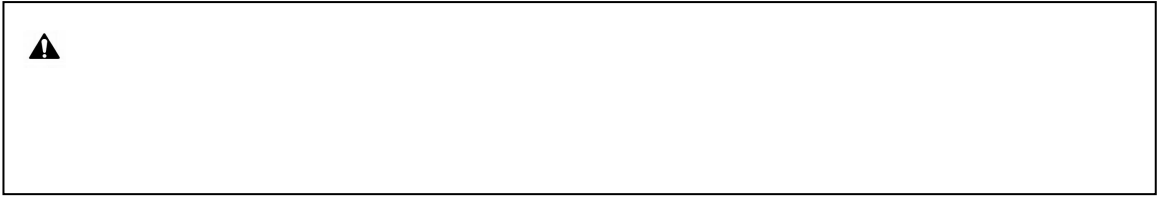



H

---



H

---

U

0% α ω ω ω ω

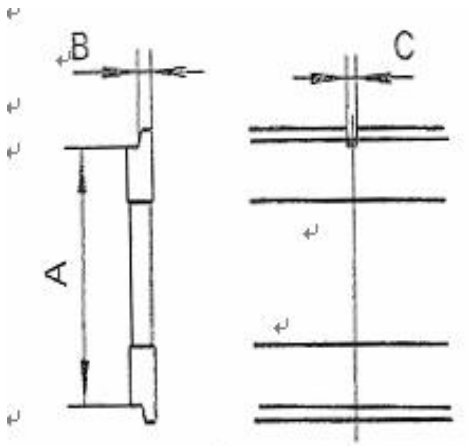



H

---



H

---





H

---







H

---



## 6.1





H

---